

TurboMAG® (The successor to HydroMAG-T)
Hexplex (Skid)

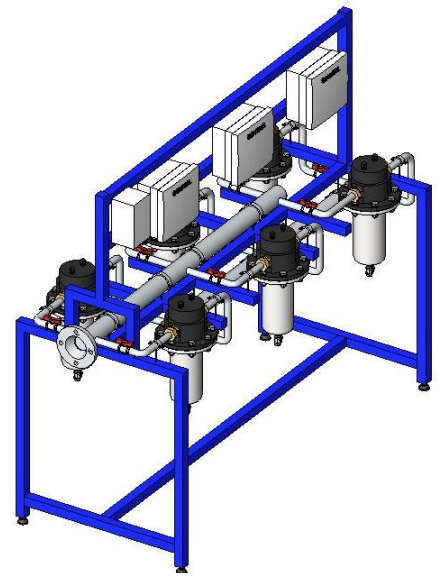

ITEM	RATING
Water Conditioning Assembly	
Performance approval	DVGW W512
Nominal flow rate	7l/s (25.2m ³ /h)
Max. inlet pressure	10bar
Pressure loss at nom. flow	1bar
Water temperature	5 – 30°C
Ambient temperature	5 – 40°C
Inlet/outlet connections	DN65 flanged
Materials of construction	
Skid frame	Aluminium
Water treatment unit	Stainless steel and POM
Weight ca.	220kg
Control Box	
Functionality and connectivity	LCD display Operational status Flow rate and treatment intensity Capacity status Error reporting BMS connection Optional remote interrogation
Power supply	230V/1ph/50Hz
Power consumption in operation	75 – 210W
Power consumption in standby	22.5W
Enclosure protection	IP65
Equipment Included	Automatic backwash filter

Advanced Scale Control by Physical Water Conditioning

For the inhibition of limescale formation in high efficiency water heaters, a Hexplex (Skid) TurboMAG® electrolytic electrochemical hybrid water conditioning unit shall be installed.

The system shall be performance approved to DVGW W512.

The operating principle shall employ cathodic induction for the formation of seed inoculation nuclei.

The system shall be environmentally friendly, operating without the need for regenerant chemicals or water wastage and shall promote optimised heat transfer within the water heater and thus contribute positively to the continued reduction of the carbon footprint.

The conditioning system shall have a flow dependant response to ensure maximum system efficiency and optimised life for the active conditioning module.

The TurboMAG® Hexplex (Skid) shall be positioned in the system subject to a system and water analysis by Hydrotec to ensure correct application of the technology.

Six treatment units, three controllers and a mains switch shall be mounted on a skid frame for the ease of installation. The controllers shall be a micro-processor based with a graphical display encased in a water resistant casing. Additionally the controllers shall monitor and record relevant parameters and operating states and provide both visual and acoustic alarms.

The controller mains switch should be connected to a 230V/1ph/50Hz supply through a 3A fused spur.

The control boxes should be rated IP65 and be provided with volt free contacts for BMS integration.

The unit is to be a TurboMAG® Hexplex (Skid) mounted unit as detailed in the adjacent technical data table.



Scale Control

TurboMAG® Hexplex (Skid)

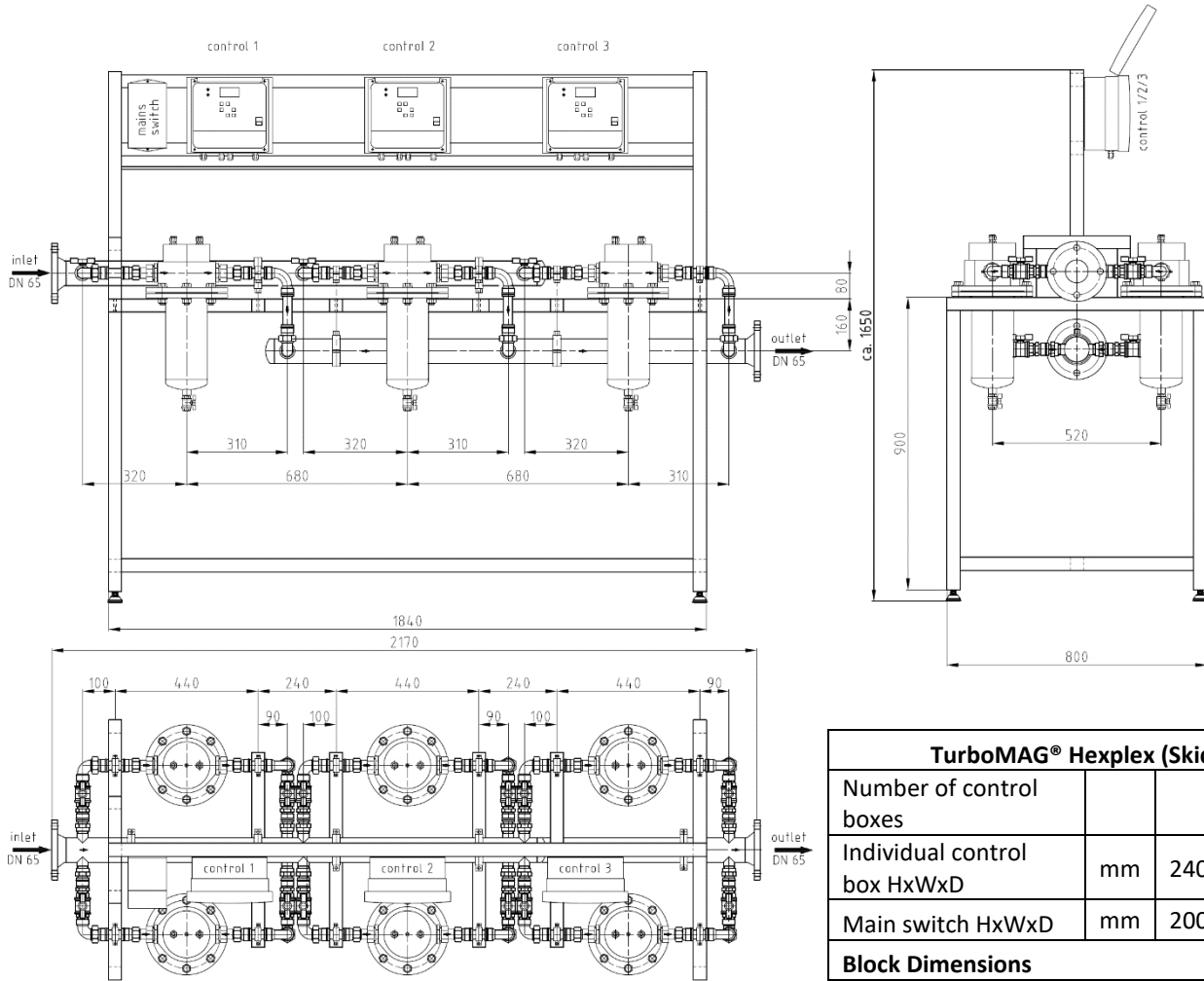

TurboMAG® Hexplex (Skid)		
Number of control boxes		3
Individual control box HxWxD	mm	240x265x145
Main switch HxWxD	mm	200x120x160
Block Dimensions		
Height (min.)	mm	ca. 1650
Width (min.)	mm	2170
Depth (min.)	mm	800

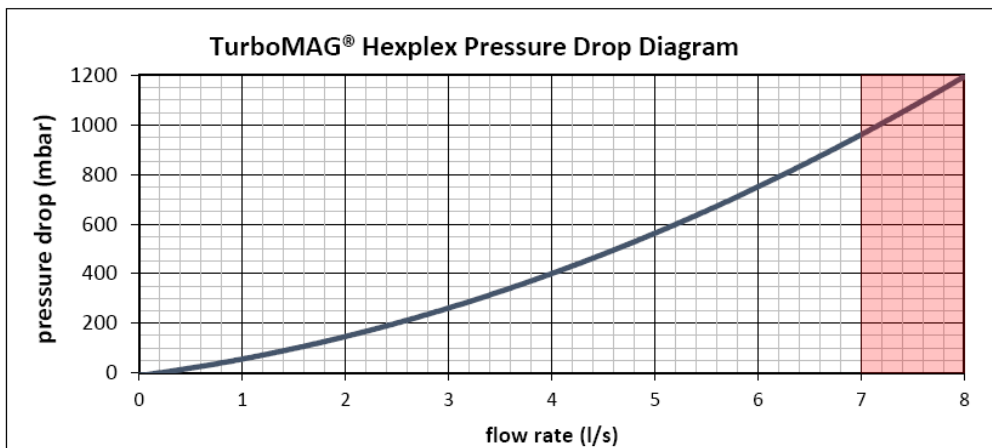

Subject to technical revisions and modifications

Hydrotec
 Hydrotec House
 5 Manor Courtyard
 Hughenden Avenue
 High Wycombe
 Bucks HP13 5RE
 Tel: +44 (0) 1494 796040
 Fax: +44 (0) 1494 796049
 E-mail: sales@hydrotec.co.uk
 Website: www.hydrotec.co.uk

For further information on the TurboMAG® range please consult your local Hydrotec technical representative.

